

REVISIONS		
REV.	DESCRIPTION	DATE
A	ADDED (2) UHMW PCS.	4/19/2024
B	UPDATED CASTERS TO 4X SWIVEL W/BRAKE & SWIVEL LOCK	4/26/2024

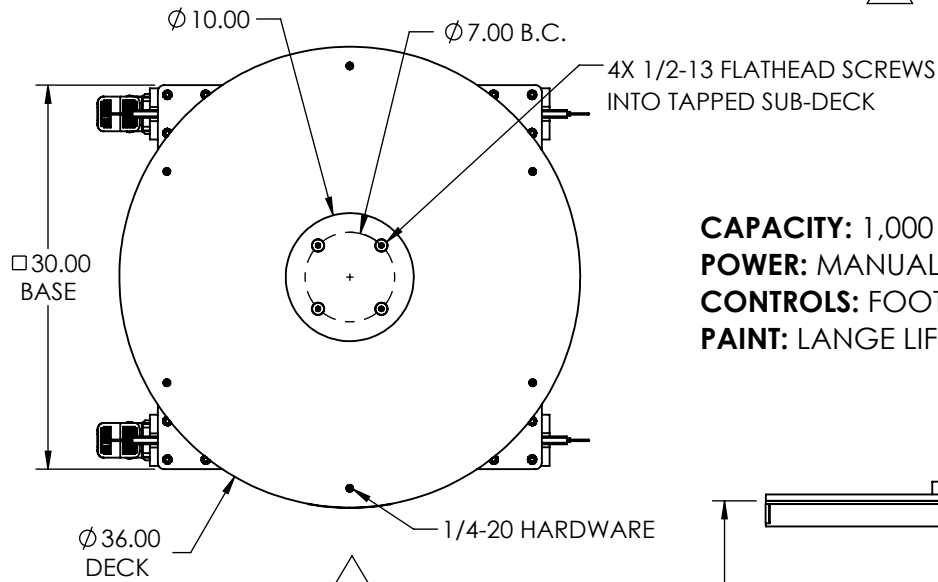

↑  
 18" TRAVEL  
 ↓

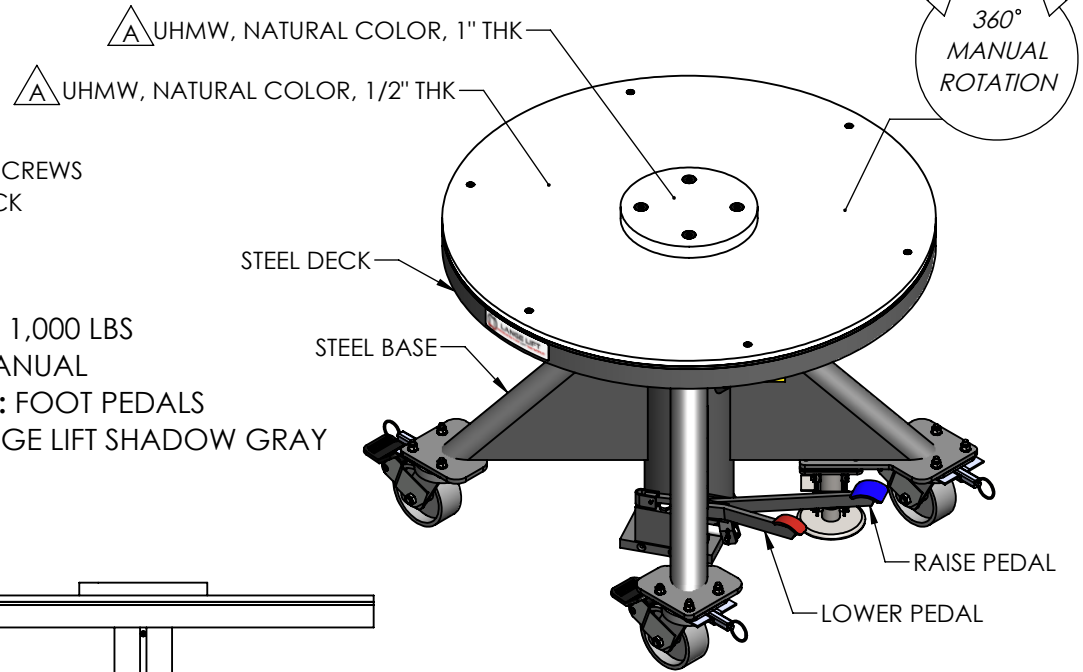
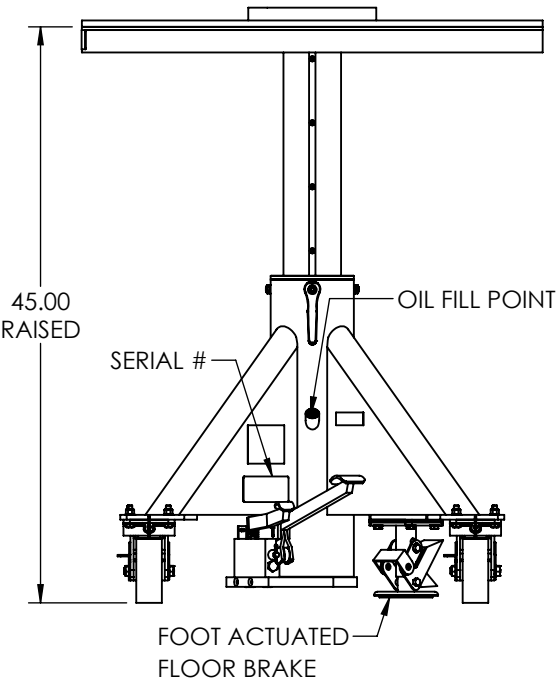
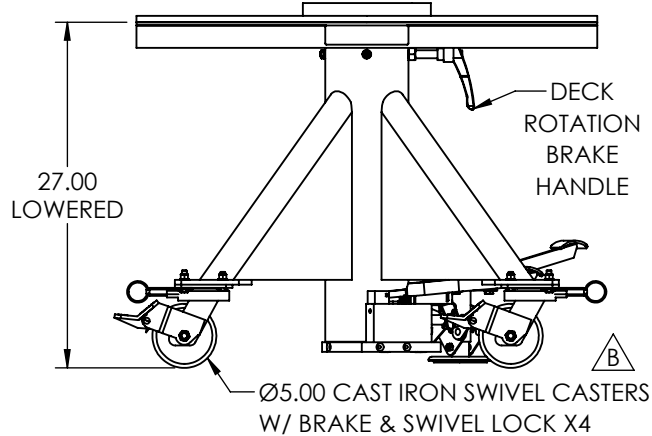

**CAPACITY: 1,000 LBS**  
**POWER: MANUAL**  
**CONTROLS: FOOT PEDALS**  
**PAINT: LANGE LIFT SHADOW GRAY**

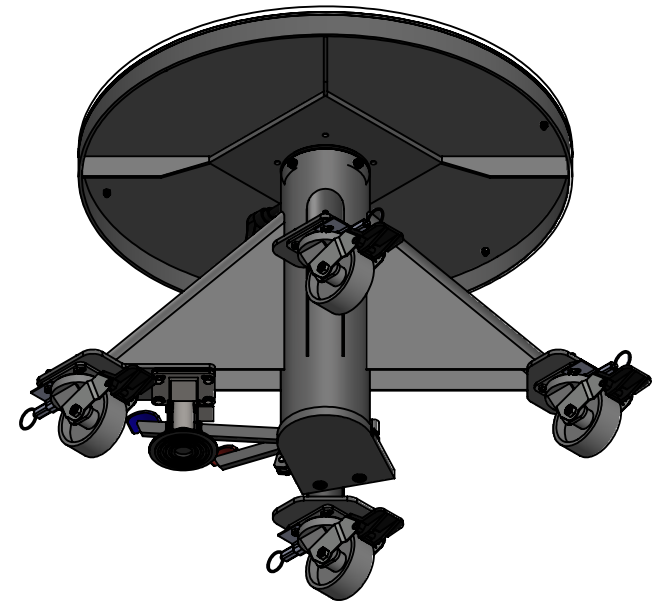

RETURN SIGNED APPROVAL DRAWING TO LANGE LIFT BY E-MAIL. LEAD TIMES ARE SUBJECT TO THE RECEIPT OF THE SIGNED APPROVAL DRAWING, AND PO, FOR ALL CUSTOM AND MODIFIED PRODUCTS.

**APPROVED FOR PRODUCTION**

PRINT NAME:	DATE:
APPROVAL SIGNATURE:	

**LANGE LIFT**  
**PRODUCTS THAT LIFT THE WORLD**  
 PO Box 580 Menomonee Falls, WI 53052  
 Phone (262) 502-0333 | langelift.com

PROPRIETARY AND CONFIDENTIAL, THE INFORMATION CONTAINED IN THIS DRAWING IS THE SOLE PROPERTY OF LANGE LIFT. ANY REPRODUCTION IN PART OR AS A WHOLE WITHOUT THE WRITTEN PERMISSION OF LANGE LIFT IS PROHIBITED.

DIMENSIONS ARE IN INCHES		DESCRIPTION:		REV:
THIRD ANGLE PROJECTION		<b>L-130 MODIFIED</b>		<b>B</b>
SCALE: NTS	DRAWN BY: DBK	DATE: 4/16/2024	DWG NO: <b>D2411944-01</b>	SHEET: 1 OF 1