

LANGE LIFT
PRODUCTS THAT LIFT THE WORLD

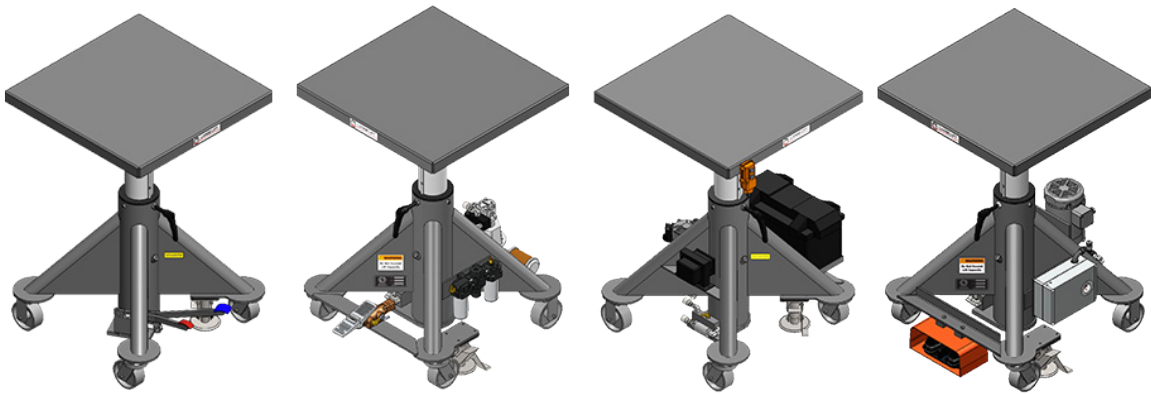

PRODUCT CATALOG



MADE IN THE USA



HISTORY OF LANGE LIFT COMPANY

Since 1934, Lange Lift has been manufacturing premium quality Hydraulic Lift Tables, Custom Scissor Lifts, Box Dumpers, Tilters/Upenders, Lift Gates, and Turntables for Material Handling in a wide array of industries across the world.

Anthony Lange, founder and creative talent, proved to be ahead of his time in his ability to design ergonomic lifts with exceptional functionality and longevity. Anthony built his brand by word of mouth, honesty, quality, and letting the product speak for itself. As Lange Lift grew, with it came a reputation of being the premiere manufacturer for Lift Tables in the world.

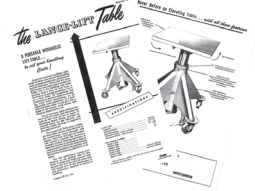

His creative vision didn't stop at his standard post-lift style product offering. Lange Lift became a world leader in solving unique challenges for customers with lifting and material handling applications that don't have a one size fits all, or off-the-shelf solution. Custom and modified designs are a core function of Lange Lift's business.

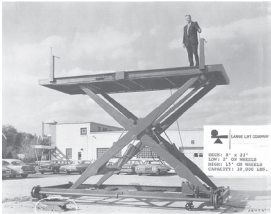

Mr. Lange was the vision and strength behind Lange Lift until his death in 1994. In early 1995, The Lange Family sold the business to Dan Knaebe, the then owner of Hevi-Haul International, Ltd. A manufacturer of industrial skates and roller dollies for the machinery moving, structural moving, and rigging industries, to name a few.

Decades prior to 1995, Lange Lift's factory used to be located in the building behind Hevi-Haul when located in Butler, Wisconsin. Dan's Grandfather, a Manager at Paul J. Kordes Co, which is now known as Hevi-Haul, knew Anthony Lange very well. He told his grandson Dan that it would be a great business for him to own one day, and urged him to pursue it. To make a long story short, he did.

In time, Hevi-Haul became the parent company of Lange Lift, and they two companies were brought under one roof in Menomonee Falls, WI. To this day, all of our products continue to be manufactured right here in the USA.

We are still a family owned small business, and we strive to carry on the traditions of our founder. We have taken advantage of investing in technological advances in manufacturing, fabrication, welding, and machining. We believe in keeping the core of our products the same level of quality, craftsmanship, and ruggedness that Lange Lift is known for.

In 2020 Dan retired and sold the business to his son Dave, whom has been with the company since 1998. Dave started his career as a welder, assembler, and machinist, which he did for many years before moving into an administrative role, and learning the clerical side of the business. Having been around the business on a daily basis with his father growing up, there is still a huge amount of pride knowing the impact our team has had across industries throughout the world. Solving our customers' challenges and helping people improve their material handling processes with ergonomic designs that assist people in working smarter is fun challenge.

We are humbled by the continued trust instilled in us by our customers, whether they be a multi-national corporations or small businesses like our own. Having the privilege of manufacturing and delivering the highest quality lifts available is a great honor.

We believe our products should be built to last, using quality raw materials, and craftsmanship. This is a standard that's hard to find in our industry today. If you're a current customer, we thank you for your continues business, and trust in us. If you're a potential customer considering us for your material handling needs we look forward to earing your business. We will continue to do our best to live up to our standards, and your expectations.



The Mission of Lange Lift is to "Create Value with Products that Lift the World."



LOCAL: (262) 502-0333 | TOLL FREE: (800) 558-0577 | EMAIL: SALES@LANGELIFT.COM

WWW.LANGELIFT.COM

PRODUCT CATALOG ERGONOMIC LIFTS



MANUAL HYDRAULIC LIFT TABLES - SQUARE DECK

CAPACITIES: 1,000 to 4,000 Pounds

RAISED HEIGHT: 45"

LOWERED HEIGHT: 27"

VERTICAL TRAVEL: 18"

DECK: 1/4" Thick, Formed & Welded Steel, 360° Continuous Rotation with Deck Rotation Lock

BASE: Formed & Welded Steel Legs, 2x Cast Iron Swivel Casters, 2x Cast Iron Rigid Casters, 1x Industrial Foot Actuated Floor Lock

POWER: Foot Pump

CONTROLS: Foot Pedals - Lift/Lower

PAINT: Lange Lift Shadow Gray

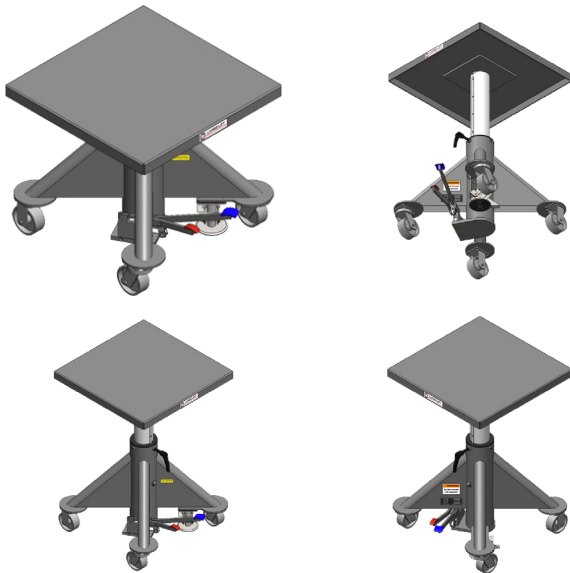

MODEL	CAPACITY	DECK & BASE SIZE
L-124	1,000 lbs.	24" Square
L-130	1,000 lbs.	30" Square
L-136	1,000 lbs.	36" Square
L-148	1,000 lbs.	48" Square
L-224	2,000 lbs.	24" Square
L-230	2,000 lbs.	30" Square
L-236	2,000 lbs.	36" Square
L-248	2,000 lbs.	48" Square
L-324	3,000 lbs.	24" Square
L-330	3,000 lbs.	30" Square
L-336	3,000 lbs.	36" Square
L-348	3,000 lbs.	48" Square
L-424	4,000 lbs.	24" Square
L-430	4,000 lbs.	30" Square
L-436	4,000 lbs.	36" Square
L-448	4,000 lbs.	48" Square



MANUAL HYDRAULIC LIFT TABLES - ROUND DECK

CAPACITIES: 1,000 to 2,000 Pounds

RAISED HEIGHT: 45"

LOWERED HEIGHT: 27"

VERTICAL TRAVEL: 18"

DECK: 1/4" Thick, Formed & Welded Steel, 360° Continuous Rotation with Deck Rotation Lock

BASE: Formed & Welded Steel Legs, 2x Cast Iron Swivel Casters, 2x Cast Iron Rigid Casters, 1x Industrial Foot Actuated Floor Lock

POWER: Foot Pump

CONTROLS: Foot Pedals - Lift/Lower

PAINT: Lange Lift Shadow Gray

MANUAL HYDRAULIC LIFT TABLES are the original Lange Lift Table, ideal for material handling in any industrial, or aerospace environment. Adjustable working heights promote safety, a reduction of bodily stress, repetitive motion injuries, and increased workflow efficiency. Ergonomic Lange Lift Tables are the perfect choice for machinists, welders, assemblers, fabricators, warehouse professionals, and more

MODEL	CAPACITY	DECK & BASE SIZE
L-124-30RD	1,000 lbs.	Ø30" Round
L-224-30RD	2,000 lbs.	Ø30" Round



MANUAL POWERED ERGONOMIC LIFTS

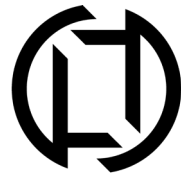

LANGE LIFT
PRODUCTS THAT LIFT THE WORLD

AIR POWER HYDRAULIC LIFT TABLES

CAPACITIES: 1,000 to 5,000 Pounds

RAISED HEIGHT: 45"

LOWERED HEIGHT: 27"

VERTICAL TRAVEL: 18"

DECK: 1/4" Thick, Formed & Welded Steel, 360° Continuous Rotation With Deck Rotation Lock

BASE: Formed & Welded Steel Legs, 2x Cast Iron Swivel Casters, 2x Cast Iron Rigid Casters, 1x Industrial Foot Actuated Floor Lock

POWER: Air Motor - 80 Psi @ 50 CFM (Recommended), Air Regulator, Filter, And Lubricator

CONTROLS: Air Valve Pedal - Lift/Lower, Adjustable Down Speed Flow Control Valve

PAINT: Lange Lift Shadow Gray

WARNING

**Do Not Exceed
Lift Capacity**



MODEL	CAPACITY	DECK & BASE SIZE
L-124-AP	1,000 lbs.	24" Square
L-130-AP	1,000 lbs.	30" Square
L-136-AP	1,000 lbs.	36" Square
L-148-AP	1,000 lbs.	48" Square
L-224-AP	2,000 lbs.	24" Square
L-230-AP	2,000 lbs.	30" Square
L-236-AP	2,000 lbs.	36" Square
L-248-AP	2,000 lbs.	48" Square
L-324-AP	3,000 lbs.	24" Square
L-330-AP	3,000 lbs.	30" Square
L-336-AP	3,000 lbs.	36" Square
L-348-AP	3,000 lbs.	48" Square
L-424-AP	4,000 lbs.	24" Square
L-430-AP	4,000 lbs.	30" Square
L-436-AP	4,000 lbs.	36" Square
L-448-AP	4,000 lbs.	48" Square
L-524-AP	5,000 lbs.	24" Square
L-530-AP	5,000 lbs.	30" Square
L-536-AP	5,000 lbs.	36" Square
L-548-AP	5,000 lbs.	48" Square

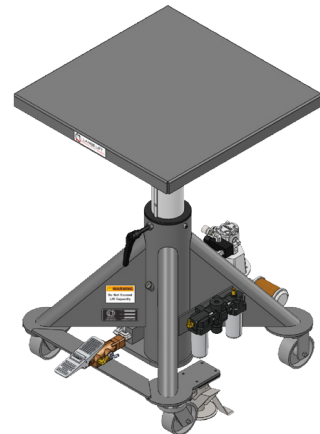
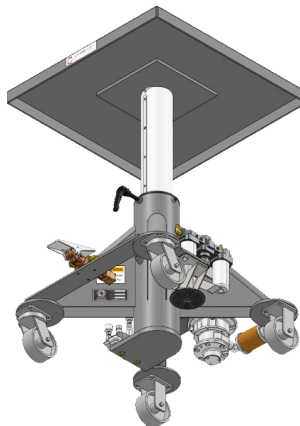
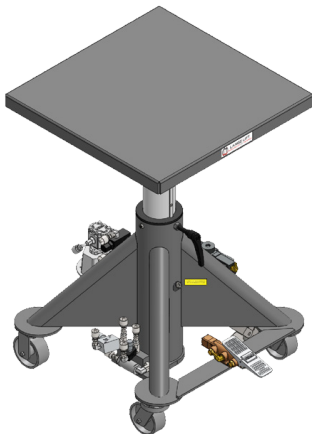

AIR POWERED HYDRAULIC LIFT TABLES are ideally suited for material handling in combustible environments, such as spray booths. They are excellent performers in any high cycle industrial, or aerospace environment where shop air is readily available. Adjustable working heights promote safety, a reduction of bodily stress, repetitive motion injuries, and increased workflow efficiency. Ergonomic Lange Lift Tables are the perfect choice for machinists, welders, assemblers, fabricators, warehouse professionals, and more.



LOCAL: (262) 502-0333 | TOLL FREE: (800) 558-0577 | EMAIL: SALES@LANGELIFT.COM

WWW.LANGELIFT.COM

AIR POWERED ERGONOMIC LIFTS



BATTERY POWER HYDRAULIC LIFT TABLES

CAPACITIES: 1,000 to 5,000 Pounds

RAISED HEIGHT: 45"

LOWERED HEIGHT: 27"

VERTICAL TRAVEL: 18"

DECK: 1/4" Thick, Formed & Welded Steel, 360° Continuous Rotation With Deck Rotation Lock

BASE: Formed & Welded Steel Legs, 2x Cast Iron Swivel Casters, 2x Cast Iron Rigid Casters, 1x Industrial Foot Actuated Floor Lock

POWER: 12 Volt Deep Cycle Battery (Enclosed), DC Motor, And On Board Battery Charger

CONTROLS: Push Button Coil Corded Pendant - Lift/Lower, Adjustable Down Speed Flow Control Valve

PAINT: Lange Lift Shadow Gray

WARNING

**Do Not Exceed
Lift Capacity**



MODEL	CAPACITY	DECK & BASE SIZE
L-124-BP	1,000 lbs.	24" Square
L-130-BP	1,000 lbs.	30" Square
L-136-BP	1,000 lbs.	36" Square
L-148-BP	1,000 lbs.	48" Square
L-224-BP	2,000 lbs.	24" Square
L-230-BP	2,000 lbs.	30" Square
L-236-BP	2,000 lbs.	36" Square
L-248-BP	2,000 lbs.	48" Square
L-324-BP	3,000 lbs.	24" Square
L-330-BP	3,000 lbs.	30" Square
L-336-BP	3,000 lbs.	36" Square
L-348-BP	3,000 lbs.	48" Square
L-424-BP	4,000 lbs.	24" Square
L-430-BP	4,000 lbs.	30" Square
L-436-BP	4,000 lbs.	36" Square
L-448-BP	4,000 lbs.	48" Square
L-524-BP	5,000 lbs.	24" Square
L-530-BP	5,000 lbs.	30" Square
L-536-BP	5,000 lbs.	36" Square
L-548-BP	5,000 lbs.	48" Square

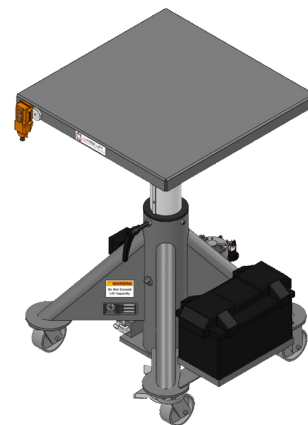
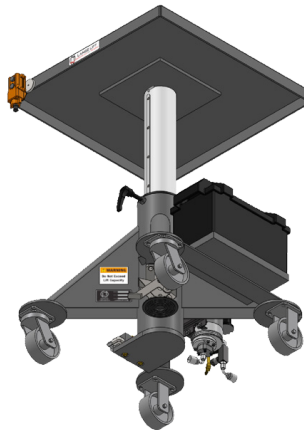
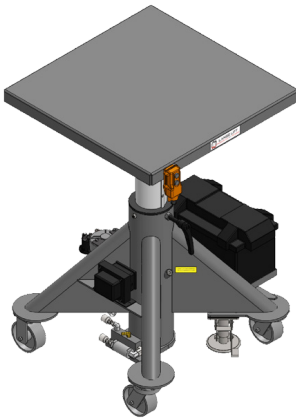

BATTERY POWERED HYDRAULIC LIFT TABLES are ideal for material handling in any industrial or aerospace environments with untethered, and high mobility needs. With no plugs, or non-integrated hoses required for use, handheld controls allow for quick, quiet, and effortless operation anywhere. The table can be charged from a standard outlet through the on-board battery charge when not in use. Adjustable working heights promote safety, a reduction of bodily stress, repetitive motion injuries, and increased workflow efficiency. Ergonomic Lange Lift Tables are the perfect choice for machinists, welders, assemblers, fabricators, warehouse professionals, and more.



BATTERY POWERED ERGONOMIC LIFTS

LOCAL: (262) 502-0333 | TOLL FREE: (800) 558-0577 | EMAIL: SALES@LANGELIFT.COM

WWW.LANGELIFT.COM



ELECTRIC POWER HYDRAULIC LIFT TABLES

CAPACITIES: 1,000 to 5,000 Pounds

RAISED HEIGHT: 45"

LOWERED HEIGHT: 27"

VERTICAL TRAVEL: 18"

DECK: 1/4" Thick, Formed & Welded Steel, 360° Continuous Rotation With Deck Rotation Lock

BASE: Formed & Welded Steel Legs, 2x Cast Iron Swivel Casters, 2x Cast Iron Rigid Casters, 1x Industrial Foot Actuated Floor Lock

POWER: 120 Volt AC Electric Over Hydraulic Motor
controls: Dual Guarded Foot Switch - Lift/Lower, Adjustable Down Speed Flow Control Valve

PAINT: Lange Lift Shadow Gray



MODEL	CAPACITY	DECK & BASE SIZE
L-124-EP	1,000 lbs.	24" Square
L-130-EP	1,000 lbs.	30" Square
L-136-EP	1,000 lbs.	36" Square
L-148-EP	1,000 lbs.	48" Square
L-224-EP	2,000 lbs.	24" Square
L-230-EP	2,000 lbs.	30" Square
L-236-EP	2,000 lbs.	36" Square
L-248-EP	2,000 lbs.	48" Square
L-324-EP	3,000 lbs.	24" Square
L-330-EP	3,000 lbs.	30" Square
L-336-EP	3,000 lbs.	36" Square
L-348-EP	3,000 lbs.	48" Square
L-424-EP	4,000 lbs.	24" Square
L-430-EP	4,000 lbs.	30" Square
L-436-EP	4,000 lbs.	36" Square
L-448-EP	4,000 lbs.	48" Square
L-524-EP	5,000 lbs.	24" Square
L-530-EP	5,000 lbs.	30" Square
L-536-EP	5,000 lbs.	36" Square
L-548-EP	5,000 lbs.	48" Square

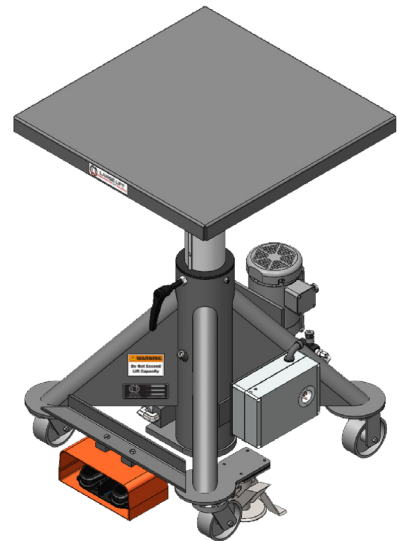
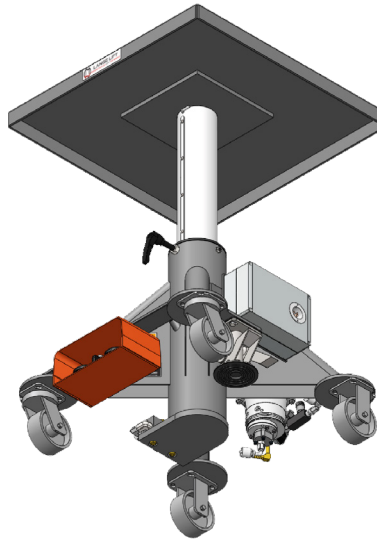
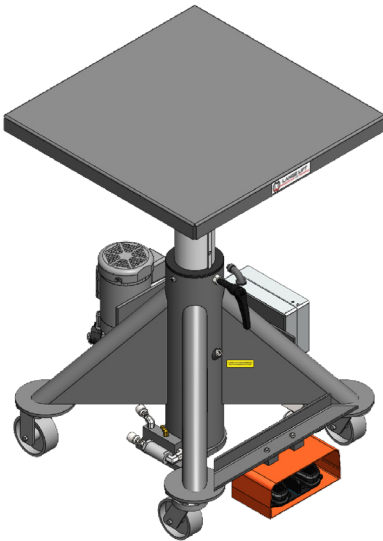

ELECTRIC POWERED HYDRAULIC LIFT TABLES are ideal for material handling in any industrial or aerospace environments with high cycle applications where raising and lowering speeds are critical for maximizing efficiency. Adjustable working heights promote safety, a reduction of bodily stress, repetitive motion injuries, and increased workflow efficiency. Ergonomic Lange Lift Tables are the perfect choice for machinists, welders, assemblers, fabricators, warehouse professionals, and more.



LOCAL: (262) 502-0333 | TOLL FREE: (800) 558-0577 | EMAIL: SALES@LANGELIFT.COM

WWW.LANGELIFT.COM

ELECTRIC POWERED ERGONOMIC LIFTS

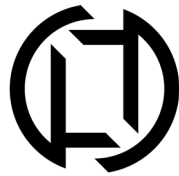

LANGELIFT
PRODUCTS THAT LIFT THE WORLD

CUSTOM & MODIFIED MATERIAL HANDLING LIFT SOLUTIONS

The **Lange Lift Custom Design & Build Shop** has extensive capabilities in designing creative, workable ergonomic solutions for your material handling needs using many different forms of material handling lifts that off-the-shelf manufacturers are unable to provide. We draw from nearly 90 years of experience in custom lift products that is unmatched in the industry. These hand built lifts are ruggedly and expertly manufactured, and built to last a lifetime. These types of lifts include Scissor Lifts, Turntables, Tilters, Box Dumpers, Up-Enders, and more. We have been entrusted with our customer's most sensitive, and

Order Process for Modified Lift Tables & Custom Products

- Modified Lift Tables are typically quoted within 1-2 business days.
- Fully Custom Products may take several weeks depending upon project complexity

Initial Inquiry

Please provide basic information about your ideal lift to sales@langelift.com. Email is preferred so we can refer back to critical details during the design process.

Common Design Parameters Include:

- Product Type - Scissor Lift, Box Dumper, Tilter, Upender, Lift Cart, Turntable
- Capacity
- Power - Manual Foot Pump, Air, Battery, Electric - All Over Hydraulic
- Footprint Size
- Ideal Raised and Lowered Heights
- Desired Movements - Lifting, Tilting, Rotating are typical
- Preferred Controls - Hand Pendants, Foot Switches, Pedals are typical
- Relevant Drawings, Sketches, or CAD Files

Internal Review

- Typical Response Time is (1) Business Day.
- Ballpark Pricing if enough information is provided to do so
- Any questions we may have or further discussions that are needed

Design Work Performed

- 3D Modeling
- Preliminary Drawings are Provided for Review or Discussion if Necessary

Finished Proposal Provided

- Approval drawing
- Quote with Pricing, Lead Time Window, and Terms of Sale
- Revision Performed if Needed

Order Requirements

- Signed Approval Drawing
- Purchase Order with Terms Matching the Quote

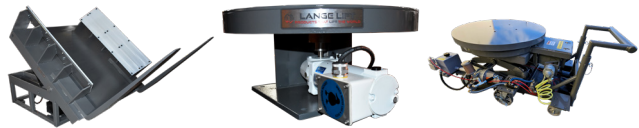

We specialize in custom modifications! The **Lange Lift Custom Design & Build Shop** is equipped to offer dynamic solutions for your unique material handling needs. We offer speedy, but detailed turnaround with up-front design, and 3D CAD models backed by nearly **90 years of field proven experience.**

Using our standard lift tables as the foundation, modifications are handled by special request.

All requests will be considered by our Sales & Engineering Team. **Common modifications include:** UHMW and Neoprene Deck Covers, Poly on Iron or Phenolic Casters, Top Lock Caster Brakes, Swivel Locks, Floor Mounting, Fork Pockets, Non-Rotating Decks, Extreme Length or Diameter, Machined Decks, Fixtures, and More.

WE MAKE MODIFICATION EASY.

More examples of our design and custom manufacturing solutions can be viewed on langelift.com.



MODIFIED & CUSTOM ERGONOMIC LIFTS

LOCAL: (262) 502-0333 | TOLL FREE: (800) 558-0577 | EMAIL: SALES@LANGELIFT.COM

WWW.LANGELIFT.COM

